

AVERY DENNISON MARKETING SPECIFICATION

HISTORY

THE SUBJECT MATTER DISCLOSED HEREIN EMBODIES PROPRIETARY INFORMATION WHICH IS THE CONFIDENTIAL PROPERTY OF THE AVERY DENNISON CO. NONE OF WHICH SHALL BE COPIED, REPRODUCED, DISCLOSED TO OTHERS, PUBLISHED OR USED IN WHOLE OR IN PART, FOR ANY PURPOSE OTHER THAN THAT FOR WHICH IT IS BEING MADE AVAILABLE WITHOUT THE EXPRESS ADVANCE WRITTEN PERMISSION OF A DULY AUTHORIZED AGENT OF THE COMPANY. THIS DOCUMENT IS THE PROPERTY OF THE AVERY DENNISON CO. AND IS TO BE RETURNED TO THE COMPANY ON DEMAND.

REV.	DATE	DESCRIPTION
A	06.23.09	RELEASE TO PRODUCTION
B	08.10.18	RELEASE UPDATES TO NEW FORMAT; ADDED -0 TO PART NUMBER; ADDED SPECIAL CHARACTERISTIC NOTE

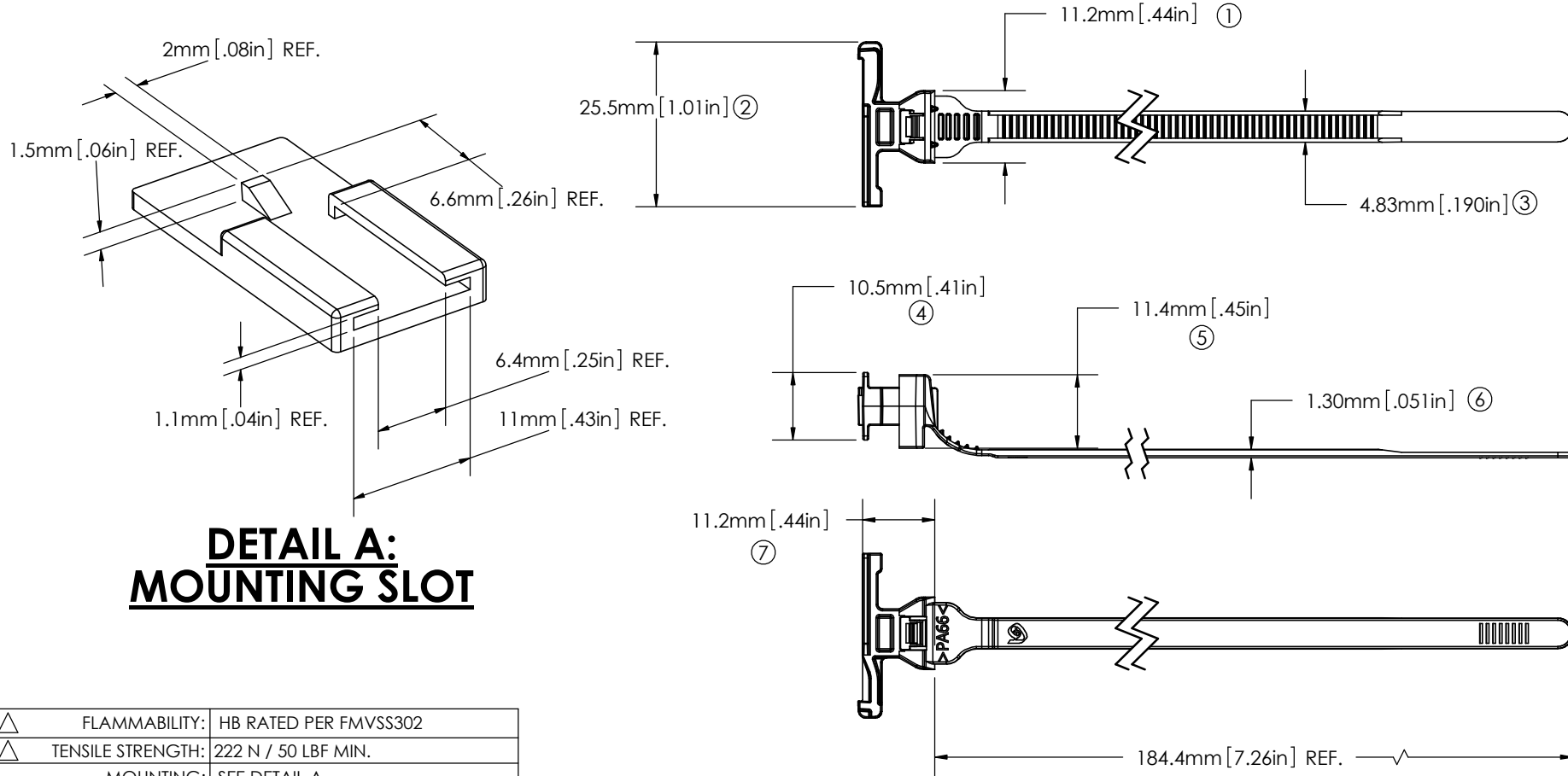

DETAIL A: MOUNTING SLOT

⑧	△	FLAMMABILITY:	HB RATED PER FMVSS302
⑨	△	TENSILE STRENGTH:	222 N / 50 LBF MIN.
		MOUNTING:	SEE DETAIL A
		TEMPERATURE RANGE:	-40°F (-40°C) TO 239°F (115°C) CONTINUOUS AND 257°F (125°C) AT MAXIMUM EXPOSURE
		WEIGHT:	2.0g
		BUNDLE DIAMETER:	∅ 1.6mm [.06in] TO ∅ 44.5mm [1.75in]
		TOOL:	12001 - HAND INSTALLATION TOOL 12500 - PNUEM. INSTALLATION TOOL
		TOOL TENSION SETTING:	6 - 8
		PACKAGING:	500/BAG, 10 BAGS/MASTER

NOTES:
1. △ = INDICATES SPECIAL CHARACTERISTIC

APPROVALS:	ENG. APPR. <i>Daniel Gilbertson</i>	08.10.18
	Q.A. APPR. <i>Rick Estano</i>	08.10.18

SPECIFIED TOLERANCES ARE:	
.XX ± .03 IN.	.X ± .7mm
.XXX ± .010 IN.	.XX ± .25mm

MATERIAL	NYLON 6/6 IMPACT MODIFIED, HEAT STABILIZED
COLOR	BLACK



DESCRIPTION	ADFM CONNECTOR TIE	
PART NO.	20124-0	REV. B